



RENTAL PACKAGE

12 Ton

Cat® air conditioning units are self-contained and provide conditioned air for indoor or outdoor rental applications. Units are sound attenuated and are equipped with high efficiency scroll-type compressors which allow for cold starting—no preheat required. Units feature rental friendly controls to meet the needs of the non-technical operator. Units designed in accordance with industry guidelines and third party safety and quality standards.

TECHNICAL SPECIFICATIONS

Model.....Stealth 12
 Dimensions – inches
 Length.....64”
 Width.....44”
 Height.....67.5”

Total shipping weight (approx lbs).....1200 lbs
 Duct connections (4) in.....13.75
 Filter – reusable.....2”x15”x20” (4)
 Single point power supply.....230 volt, 3 phase,
 60 HZ with ground

TECHNICAL DATA

Electrical Data Total full load amps or running load amps		230 volt, 3 phase, 60 HZ with ground 96.3
System Control Remote Temperature Control Discharge air temperature control Return air temperature control		Standard Standard Standard
Fan Data Design air flow/maximum air flow Design total static pressure Fan type Fan control Motor power/speed	cfm in wg hp/rpm	4050 3.25 Centrifugal VFD 5/1750
Cooling Data Design capacity Design conditions: Entering air temp (dry bulb/wet bulb) Leaving air temp (dry bulb/wet bulb) Coil construction Rows Fins per inch Low ambient control	tons °F °F	12 90/70 63.5/59.6 Copper Tube/Aluminum fins 4 12 VFD
Compressor Data Type		High Efficiency Scroll



DIMENSIONS

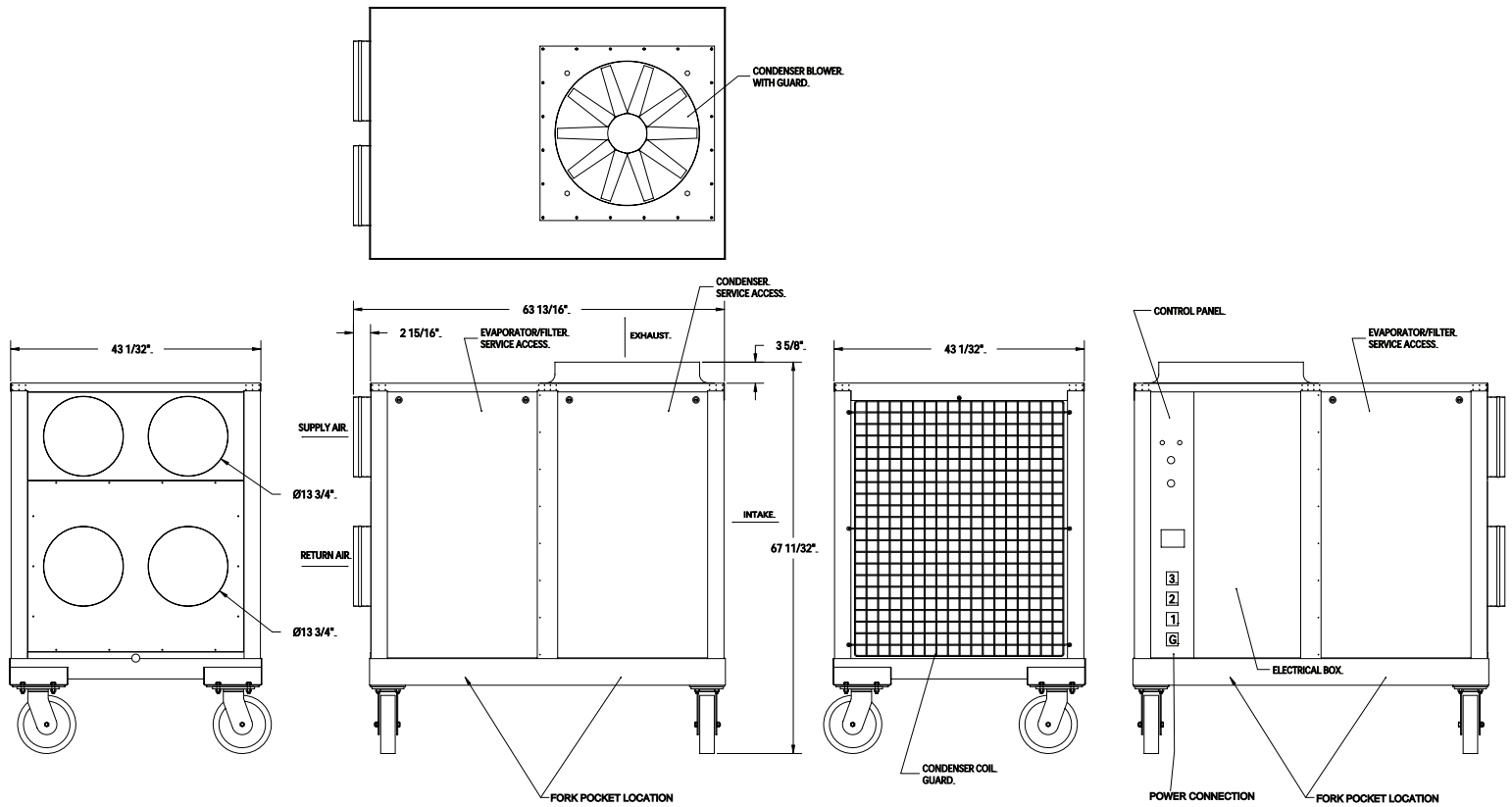

Consult your Caterpillar representative for more details.

www.CAT-ElectricPower.com

©2003 Caterpillar

All rights reserved.

Printed in U.S.A.

LEHX3876 (1-03)

Materials and specifications are subject to change without notice.

